

KONIG

THE BAKER'S
CROWN

REX FUTURA MULTI

THE DOUGH DIVIDING AND
ROUNDING MACHINE WITH
EXTENDED WEIGHT RANGE



DIVIDING & ROUNDING

MAIN FEATURES

DOUGH DIVIDING AND ROUNDING MACHINE REX FUTURA MULTI

- weight range of 12 to 245g (up to 600g for only divided products) adjustable with touch panel
- hourly output rate of up to 12,000 pieces at 8-row operation (25 strokes/min)
- simple change of the dividing drum ledges for different weight ranges or to change the number of rows
- optimal rounding results due to exchangeable rounding plates and electrically adjustable rounding eccentric
- demountable dough hopper with infeed rollers, removable hopper duster unit, rounding plates and drum ledges allow easy cleaning of the machine
- simple cleaning and maintenance due to extensive operation doors
- PLC control and touchpanel enables a quick installation

- exchangeable dividing drum ledges allow the installation of special stamping tools or rustica stamps for the production of angular, rustic rolls
- massive cast side plates for ideal vibration damping during operation
- dough hopper with infeed roller with safety light-grid and a maximum capacity of 28 liter as standard
- generous and ergonomically engineered storage surface for dividing drum ledges and dividing slide blocks
- machine weight: approx. 1,100 kg
- rated power supply: 2 kW



REX FUTURA MULTI BREAD ROLL LINE

- hourly capacity of up to 12,000 pieces at 8-row operation and a weight range of 12 to 245g (up to 600g for only divided products)
- increased product range by combining the dough dividing and rounding machine Rex Futura Multi with established Koenig downstream units (eg. pre-rolling unit, prover, stamping station, forming station, seeding unit, retracting unit etc.)
- production of for example rounded, rounded stamped and long rolled products (Baguette), Bolillos, longrolled convoluted products (Kornspitz), flattened products (Hamburger), tin bread etc.

WORKING PRINCIPLE

- The dough is filled by hand into the hopper with infeed rollers.
- The rotating dough feeding stars cut the dough into suitable portions (depending on the selected dough piece weight) and transfer it to the dividing area.
- The horizontal slider pushes the dough into the recesses of the rotating dividing drum. The excess dough is removed by the scraper bar and returned to the dividing area.
- After a 90° counterclockwise rotation, the dough pieces are kneaded with an oscillating kneading plate. The speed of the knitting plate and the deflection of the knitting eccentric can be adjusted for optimum knitting results with different dough consistencies and weights.
- The weighing drum is equipped with **two** different sets of weighing bars for an extended weight range.

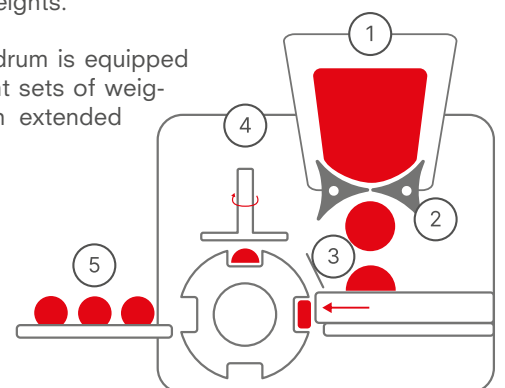

MAIN DIMENSIONS

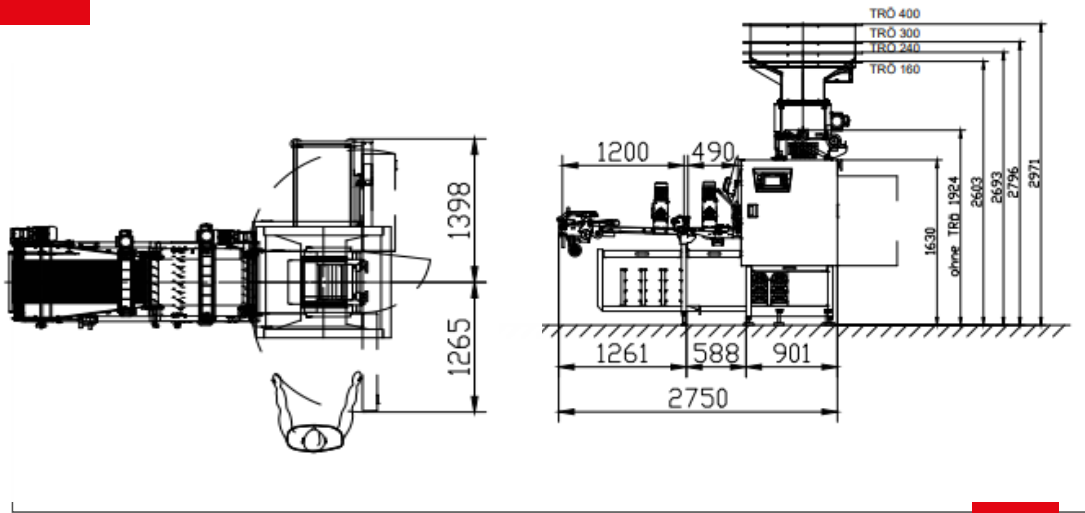

WEIGHT RANGES

Weight ranges (depending on dough)	Number of rows	Hourly capacity	combination	rounded / not rounded	Strokes / minute
12-16g	8	12000			25
15-19g	8	12000			25
17-33g	8	12000			25
17-33g	(3)\4\5\6	4500/6000/7500/9000			25
20-47g	(3)\4\5\6	4500/6000/7500/9000			25
22-55g	(3)\4\5\6	4500/6000/7500/9000			25
25-65g	(3)\4\5\6	4500/6000/7500/9000			25
35-80g	(3)\4\5\6	4500/6000/7500/9000			25
50-105g	(3)\4\5\6	4500/6000/7500/9000			25
52-110g	(3)\4\5\6	4500/6000/7500/9000	all weight ranges can be combined with changeable dividing ledges in combination with a spreading finger belt	rounded	25
55-125g	(3)\4\5	4500/6000/7500		25	
60-130g	(3)\4\5	4500/6000/7500		25	
65-160g	(3)\4\5	4500/6000/7500		25	
95-165g	(3)\4\5	4500/6000/7500		25	
100-170g	(3)\4\5	4500/6000/7500		25	
95-180g	(3)\4	3600/4800		25	
100-210g	(3)\4	3600/4800		25	
140-245g	(3)\4	3600/4800		25	
200-300g	3	4500		25	
200-400g	2	2160	not rounded	25	
300-600g	1	1500		25	



SERVICE & SPARE PARTS FROM THE MANUFACTURER!

Every machine and system is tested with dough and run in before it leaves Koenig's premises. Our technicians have profound education and years of experience in bakery technology. They assemble the equipment at Koenig and then commission it at your site. And should a problem ever arise, our spare parts and service department is at your disposal. Day and night. Worldwide.



During office hours: **+43 316 6901 0**

Outside office hours: **+43 316 6901 739 1 (mechanical)**

+43 316 6901 739 2 (electrical)



KONIG

QR code for more information about
the Rex Futura Multi